

DO3500 Dissolved Oxygen Controller / Transmitter

Operating Manual



CLEAN Instruments Co.,Ltd



Web: www.cleaninst.com

www.cleaninst.com

TEL :+ 86 - 21 - 63531465

Add : 8B212 No. 215, Yin Du West Road, Song Jiang Dist.,
Shanghai China

CLEAN Instruments Co.,Ltd

XII、Table of oxygen saturation concentrations in water at different temperatures

Atmospheric pressure of 101325Pa, humidity of 100%RH, and salt content of 0%

temperature	Dissolved oxygen	temperature	Dissolved oxygen
0	14.64	20	9.08
1	14.22	21	8.90
2	13.82	22	8.73
3	13.44	23	8.57
4	13.09	24	8.41
5	12.74	25	8.25
6	12.42	26	8.11
7	12.11	27	7.96
8	11.81	28	7.82
9	11.53	29	7.69
10	11.26	30	7.56
11	11.01	31	7.43
12	10.77	32	7.30
13	10.53	33	7.18
14	10.30	34	7.07
15	10.08	35	6.95
16	9.86	36	6.84
17	9.66	37	6.73
18	9.46	38	6.63
19	9.27	39	6.53

Note: taken from Table A1 of Determination of GB / T 11913-1989

catalogue

First, to inform users.....	3
II. Product inspection.....	3
III., Instrument, Introduction.....	3
IV. Technical parameters.....	4
V. Instrument installation method.....	5
VI. Wiring label.....	6
VII. Key description.....	7
VIII. Measurement mode.....	8
IX. Browse mode.....	9
X. Calibration mode.....	11
1. Go to the calibration menu.....	11
2. Calibration interface description.....	11
3. Description of the dissolved oxygen electrode calibration.....	11
4. The calibration process of the oxygen-soluble electrode.....	12
XI. Set up the mode.....	14
1. Go to the Settings menu.....	14
2. Set up the menu key description.....	14
3. Description of the System Settings menu options.....	15
4. Parameter setting menu options description.....	15
5. Run the Settings menu option description.....	18
6. Set the default list of menu options.....	20
Twelve. Information Mode.....	21
XIII. Communication Agreement.....	21
1. Communication Introduction.....	21
2. data format.....	21
3. Floating whole register group (20 addresses ranging from 0 x 0000 to 0 x 0013).....	23
4. Floating floating-point register group (20 addresses from 0 x 0000-0 ~ 0 x 0013).....	25
5. Keep the register group (40 addresses from 0 x 0014 to 0 x 003 B).....	27

6. Control the transfer register group (with 20 addresses ranging from 0 x 0050 to 0 x 0063).....	31
7. Information register group (20 addresses from 0 x 003 C to 0 x 004 F).....	32
8. Communication control calibration.....	33
9. Communication parameter setting.....	35
10. Unit code table.....	36
XIV. Use and maintenance of electrodes.....	37
1. dead work.....	37
2. , recommend.....	38
3. , maintenance.....	38
4. , calibration.....	38
5. , preserve.....	39
6. , age.....	39
7. The electrode technical parameters.....	39
8. Change the electrode membrane cover.....	39
XV. Oxygen saturation concentration table in water at different temperatures.....	40

5. preserve

During the interval of the test sample solution, immerse the electrode head in distilled water and keep the electrode connected to the instrument, left open so that the electrode can remain polarized.

Long-term storage of electrodes. The electrode should be removed from the instrument and the probe stored in a wet vault or electrode head protective cap.

6. age

Note that each electrode ages with an increasing number of use, resulting in a slow electrode response and a gradually smaller slope. In addition, the wrong preservation, specific media will shorten the electrode service life.

We do not provide a warranty for electrode failure or mechanical damage due to the testing media.

7. Electrode technical parameters

Allow to use the temperature range: 0 to 60°C

Maximum pressure is allowed: 4 bar

Minimum flow rate requirement: 0.05 m / s

Temperature sensor type: NTC 22KΩ

Response time: values over 90% within 60 seconds

8. Replacement of electrode membrane sleeve

After use for a long time, perhaps this electrode may have slow reading or even no response problems, which is generally due to the electrode membrane cap is often contaminated by the sample solution, resulting in damage or debris, this time needs to replace the motor membrane cap. Refer to Preparation for replacing the electrode membrane cap.

Damaged or sundry electrode membrane caps will result in very poor measurement performance and incorrect test data.

2. recommend

Water samples were measured on site and in the laboratory. If the service environment is exceeded, the electrode service life may be affected (see technical parameters).

3. maintenance

The anode (silver tube) and cathode (platinum needle, or white gold needle) parts in the electrode need to be regularly wiped with a polished cloth to keep them in their best condition.

When wiping, spin down the electrode cap, expose the anode and cathode parts, and then wipe it carefully with the polishing cloth brought with the electrode. Pay attention to the appropriate force, especially when wiping the pressure can not be too big, as long as these parts clean surface, a bright color. Then use distilled water and then rinse the parts with alcohol. Finally dried and reassembled onto the electrode.

4. calibration

① Connect the electrode to the dissolved oxygen tester and switch on the instrument power switch to polarize the electrode. The polarization time takes approximately 15 to 20 minutes.

② Place electrodes in an environment or condition saturated with dissolved oxygen and shall be adjusted according to the dissolved oxygen tester instructions. This step requires repetition several times depending on the environment where the sample is tested.

③ Put the electrode head into a beaker with anaerobic distilled water (anaerobic distilled water can be prepared by filling a beaker with nitrogen for about 20 minutes. It can also be prepared by adding a saturated anhydrous sodium bisulfite [Na₂S₂O₃] at 50ml of distilled water.) When the reading is stable, operate the instrument so that the reading is zero.

④ The electrodes are rinsed with distilled water, when the measurements can be started. When measuring, place the electrode probe approximately 1.5 inches (about 6 cm) below the surface of the sample solution. After the reading is stable, note the reading.

I、 To inform the user

Thank you for supporting your company. Please read the instructions in detail to help you use our products correctly.

II、 Product inspection

Carefully open the package, check the instrument for damage and complete accessories, if any abnormality, please contact the dealer or the company immediately.

In any event shall the instrument be removed by itself, and the Company is no longer responsible for the warranty.

III、 Instrument, introduction

● 128 * 64 dot-matrix LCD display, switchable in Chinese and English, IP65 protection level, all-weather stable operation

● simple menu design, simple and convenient operation, graphical prompt, beautiful and clear interface

● software digital filtering is adjustable, with enhanced hardware resistance to interference, making measurements more stable and adapted to complex industrial environments

● global access power supply 85~260VAC, but also customized DC model 18 to 36 V D C

● RS-485 digital interface, MODBUS-RTU communication protocol, read and write two-way communication, can achieve remote complete control of the instrument

The ● is compatible with two types of electrodes, 400nA or 80nA

IV、technical parameter

oxygen concentration DO mg/L	measuring range	0.00~40.00 m g/L
	resolution ratio	0.01 m g/L
	Measurement accuracy (electronic unit)	±0.05 m g/L
Percentage oxygen content DO %	measuring range	0.0~400.0 %
	resolution ratio	0.1 %
	Measurement accuracy (electronic unit)	±0.5 %
temperature	measuring range	-5.0~105°C.0
	resolution ratio	0.1°C
	Measurement accuracy (electronic unit)	±0.3°C
	Temperature input	NTC22K
	Temperature compensation	Automatic / manual
Transfer current	Output, type	Two roads of 4~20 mA (the corresponding range can be set)
	Current accuracy	±1% F.S
	output loading	less-than 500Ω
control	Functional relay	One (which can be set to the cleaning or alarm function)
	Switch relay	2 SPST relays
	load capacity	2.5A 230VAC
data transmission	coffret	All-way RS485 isolation voltage is 2500Vrms
	protocol	MODBUS-RTU (read-write two-way communication)
Other parameters	working power supply	85~260VAC or 18~36VDC (optional before order)
	working temperature	0~60°C
	Work humidity	Relative humidity was <90%
	levels of protection	IP65
	way to install	Disk installation
	outline dimension	(H×W×D) 108×108×132 mm
	Open hole size	92.592.5 mm (positive tolerance)

XI、 Electrode use and maintenance

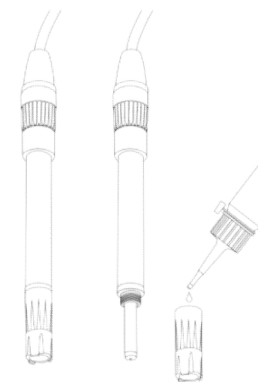

1. dead work

- ① Spin down the oxygen-soluble membrane cap fittings from the electrode cylinder.
- ② Wash the internal cathode / anode sections with distilled water and then dry with a clean rag.
- ③ Add the electrode's own filling fluid to the oxygen-soluble membrane cap accessory, and then rotate the membrane cap filled with the filling fluid and assemble it on the electrode cylinder. Some solutions may flow from some thread during assembly, which is a normal phenomenon, with no problem. Try to tighten the cap slowly to exclude air and ensure that the cap is tightly connected to the cylinder, but not too hard.
- ④ Observe the lytic oxygen membrane to ensure that the cathode part inside the electrode is connected to the lytic oxygen membrane. Note: The oxygen-soluble membrane must be tight without any folds or damage.
- ⑤ The assembled electrodes were rinsed with distilled water and then dried with a clean cloth so that the electrodes could be used.
- ⑥ Calibrate and measurement according to the instrument manual.

10. Unit code table

unit	Code hexagon	Code decimal	unit	Code hexagon	Code decimal
mV	0x00	0	ug/L	0x0D	13
nA	0x01	1	mg/L	0x0E	14
uA	0x02	2	g/L	0x0F	15
mA	0x03	3	ppb	0x10	16
Ω	0x04	4	ppm	0x11	17
K Ω	0x05	5	ppt	0x12	18
M Ω	0x06	6	%	0x13	19
uS/cm	0x07	7	mbar	0x14	20
mS/cm	0x08	8	bar	0x15	21
S/cm	0x09	9	mmHg	0x16	22
pH	0x0A	10			
$^{\circ}\text{C}$	0x0B	11			
$^{\circ}\text{F}$	0x0C	12			

Instrument installation mode

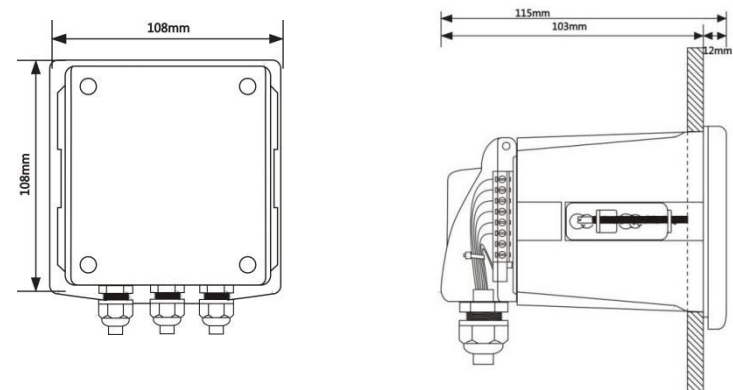

1. Install the opening size 92.5×92.5mm (positive tolerance)
2. It is recommended to use 0.5 to 1 square wire, through the middle waterproof harness head, with a certain length margin.

V、Terminal label

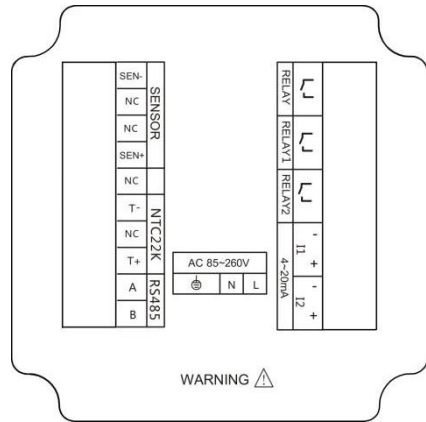

binding post	function	binding post	function
SEN-	Dissolved oxygen electrode anode (anode)	RELAY	Functional Relay (cleaning / alarm)
NC	united	RELAY1	electric relay 1
NC	united	RELAY2	electric relay 2
SEN+	Dissolved oxygen electrode cathode (cathode)	I1-	4~20mA output channel 1, negative end
NC	united	I1+	4~20mA output channel 1, positive end
T-	NTC22K	I2-	4~The 20mA output channel 2, at the negative end
NC	united	I2+	4~20mA output channel 2, positive end
T+	NTC22K	⊕	Power grounding line
A	RS-485 Communication T / R +	N	Power zero line
B	RS-485 Communication T / R-	L	Power line

Note: This wiring diagram is illustrated with 220V AC, if the user customized 24V DC.

9. Communication parameter setting

The contents in the instrument setting menu can be set through the communication function, they are located in the holding register group and the control transmission register group, the holding register group can be written with 0x06 function code, the control transmission register group can be written with 0x10 function code, and can refer to the corresponding subsection.

When setting these parameters, the instrument should be in the menu state of the setting mode. Therefore, in the measurement mode, the calibration mode code 0x0050 is first written to the working mode register (address 64) to enable the instrument to enter the setting mode.

If the password is not set (0000), the instrument goes directly to the Settings menu (Work event register (address 66) value is 1)

If the password is set (not 0000), the instrument displays the password data interface (working event register (address 66) value is 0). The password can be written in the working mode parameter register (address 65), and the password is correct to enter the setting menu.

Set the menu interface to write the following values to the working mode parameter register (address 65)

0x7FFF: The instrument resumes the factory operation

0x7FFE: The instrument performs the restart operation

liquid code Calibrate the state register (address 67), or The electrode calibration case register (address 25), to initiate the calibration.

□ step 3:

Read the calibration state register (address 67) to determine the current calibration status, and the register value and calibration status are as follows,

0x0000: Calibrated successfully (calibration menu returned)

0x0001: Calibration (you can read the calibration status register later)

0x0002: Wrong buffer (returned to calibration menu)

0x0003: Calibration measurement signal stabilized for long time (180 seconds) (calibration menu returned)

0x0004: Electrode slope or zero-point offset out of range (Calibration menu returned)

0x0005: Wrong calibration order (calibration menu returned)

If the calibration is successful, repeat steps 2 and 3 to continue to calibrate the other points. Other errors were recalibrated by prompting for excluding errors. To return to the measurement mode, it is available at The working mode register (address 64) writes to the measurement mode code 0x0010. The electrode calibration, electrode zero point offset and slope can be viewed in the holding register group at any time.

② Calibrate point code





100% Point code is 1 (0x0001) (Binary BIT0)

0% Point code is 2 (0x0002) (Binary BIT1)





Calibration follows the rule of 100% point first, after successfully calibrating 100% points, the value of the electrode calibrated case register (address 25) is 0x0001 (binary BIT0 is positioned), after continuing successfully calibrating 0% points, the value of the electrode calibrated case register is 0x0003 (binary BIT1 is also placed).

To clear the calibration data, write to the standard fluid code 0x7FFF.

Key instructions

key	Key function description
	<p>Press this key in measurement mode to enter browse mode to browse the measurement related values</p> <p>Browse to continue in browse mode until measurement mode</p> <p>Press this key in another mode to return the key</p>
	<p>Press this key in the measurement mode to enter the calibration mode</p> <p>Press this button to move the option up when the menu interface has the ▲ symbol</p> <p>This key is the value up key</p>
	<p>Press this key in measurement mode to enter the Settings menu</p> <p>Press this button to move down the option when the menu interface has the ▼ symbol</p> <p>This key is the value is set</p>
	<p>In measurement mode, this key enters the information mode and continue to view the set parameters and instrument information</p> <p>Press this button to switch with symbols on the menu interface to the next menu</p> <p>This key is used as the numerical shift key when the value is set</p>
	<p>Press this key in browsing mode to lock the current browsing interface (prevent the browsing timeout from returning the measurement automatically)</p> <p>Press this key for confirmation in another mode</p>

Key instructions

key	Key function description
	<p>Press this key in measurement mode to enter browse mode to browse the measurement related values</p> <p>Browse to continue in browse mode until measurement mode</p> <p>Press this key in another mode to return the key</p>
	<p>Press this key in the measurement mode to enter the calibration mode</p> <p>Press this button to move the option up when the menu interface has the ▲ symbol</p> <p>This key is the value up key</p>
	<p>Press this key in measurement mode to enter the Settings menu</p> <p>Press this button to move down the option when the menu interface has the ▼ symbol</p> <p>This key is the value is set</p>
	<p>In measurement mode, this key enters the information mode and continue to view the set parameters and instrument information</p> <p>Press this button to switch with symbols on the menu interface to the next menu</p> <p>This key is used as the numerical shift key when the value is set</p>
	<p>Press this key in browsing mode to lock the current browsing interface (prevent the browsing timeout from returning the measurement automatically)</p> <p>Press this key for confirmation in another mode</p>

□ Address 64: Working mode. This register value reflects the current working mode of the instrument. The corresponding value of the working mode to the register can control the instrument to enter the corresponding mode. The corresponding relationship is as follows, and the value is defined in a 16 decimal mode.

0x0010: Measurement mode





0x0020: Information mode

0x0030: Browse mode

0x0050: Set the mode

0x0060: The calibration mode

□ Address 65: Working mode parameters for some operations in instrument control, see specific application. Generally alternative keys, the correspondence is as follows, the values are defined in a 16 decimal mode.

0x0001:  0x0002:  0x0003:  0x0004:  0x0006: 

□ Address 66: Work event, this register value reflects an event where the current instrument is in working mode, and the user generally does not need to care about it.

□ Address 67: Calibration status for electrode calibration operation, refer to the Communication Control Calibration Section.

□ Address 68, 69, 79, 71, 72, 73: Basic information of the instrument, and the values are defined in a 16 decimal mode.

8. Communication control calibration

① Calibrate step instructions

Users can use the communication function to control the instrument and complete the electrode calibration operation. Please read the Calibration Mode section for the electrode calibration rules. Communication calibration steps are as follows.

□ step 1:

Place the electrodes in the buffer or standard solution.

□ step 2:

Under the measurement mode or calibration menu, write the standard

the allowable range and minimum interval, please refer to 11.5.④⑤。Read and write is 100 times when controlled with D 0 mg/L, 10 times for DO%, and 10 times when controlled with temperature values.

For example, when a device is controlled with D 0 mg/L oxygen, reading the register value of 1000 indicating 10.00mg/L, to set a value of 5.00 mg/L, the minimum interval corresponding to the 500,40 m A and 20mA is 2.00mg / L.

□ Address 84,85: Two parameters of the functional relay. The value of the register is the integer type, and when the parameter 1 value is 0, the functional relay is the alarm mode. When the value of parameter 1 is 1~1000, the functional relay is cleaning mode, and the value of parameter 1 is cleaning interval in hours. The value of parameter 2 is in cleaning mode, indicating the cleaning duration, range 1~1000, per seconds.

7. Information register group (20 addresses from 0x003C~0x004F)

The information register contains the instrument running status and information, such as the version number, serial number, etc., and is read using the function code 0x03. You can also use the function code 0x06 to modify the relevant register value of the instrument operating status, and control the instrument for electrode calibration and other operations.

register	address hexadecimal	address decimal system	name	type	attribute	remarks
keep register	0x 003C~0x	60~63				
	0x 0040	64	work pattern	inte	R/W	
	0x 0041	65	Working mode	inte	R/W	
	0x 0042	66	Work events	inte	R	
FC	0x 0043	67	Calibration status	inte	R/W	See also those
0x 03	0x 0044	68	Instrument type	inte	R	
fetch	0x 0045	69	Instrument model	inte	R	
FC	0x 0046	70	software release	inte	R	
0x06	0x 0047	71	Hardware version	inte	R	
write in	0x 0048	72	serial number	inte	R	
	0x 0049	73	serial number	inte	R	
	0x 004A~0x	74~79				

Browse mode



In the measurement mode, the keys enter the browsing mode. If there are multiple browsing pages, continue to browse in turn until the measurement mode is returned. The browsing mode mainly displays the electrode signal and the calibration situation and other parameters, as a supplement to the main display interface. One-minute no-button operation will automatically return to the measurement mode. If it needs a long time to view, you can lock the current interface, and then the key can exit the lock. The interface is shown below.



below.

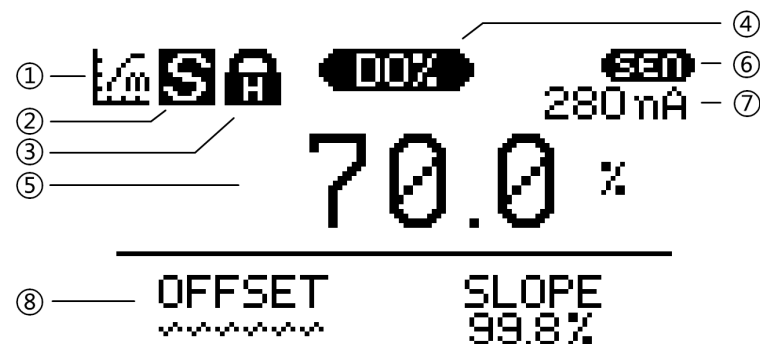

- ① Working mode indicates, Browse mode.
- ② The main display area measures the stability symbol, indicating that the main display area value is stable.
- ③ Interface lock symbol, press ENT key in browsing mode to lock the current interface, to prevent the automatic return of measurement mode without operation.
- ④ Measurement value type in the main display area. DO: oxygen concentration (D 0 mg/L). DO%: percent oxygen content (DO%).
- ⑤ Main display area measurements. If OVER indicates the upper limit, UNDER indicates the upper limit.

- ⑥ Secondary measurement value type. SEN: The electrode signal value.
- ⑦ Sub-measurement value display area. If OVER indicates the upper limit, UNDER indicates the upper limit
- ⑧ Electrode calibration information display area. OFFSET: Zero-point offset. SLOPE: Slope. Some values indicate that the corresponding point has been successfully calibrated. Wave lines indicate uncalibration or calibration failure.

6. Control transfer register group (20 addresses from 0x0050~0x0063)

The relay switch value and the transmission current corresponding value set by the control transmission register for the user are read using the function code 0x03. When the instrument is in the setting menu interface (setting state), you must use the function code 0x10 to write the value of the two registers of one device at a time. For example, a closed value and a disconnected value of a relay. Of course, they are also continuous in the address. The address list is as follows. Property bar R is readable, W is writable, and D indicates factory recovery. This register is restored to the default value. Default reference 9.6, Set the default list of menu options.

register	address hexadecimal	address decimal system	name	type	attribute	remarks
control	0x 0050	80	4~Corresponding value of	inte	R/W/D	Function code 0x 10 is written
	0x 0051	81	4~Corresponding values	inte	R/W/D	
Change send	0x 0052	82	4~Corresponding value of	inte	R/W/D	Function code 0x 10 is written
	0x 0053	83	4~Corresponding values	inte	R/W/D	
register	0x 0054	84	Function relay parameter 1	inte	R/W/D	Function code 0x 10 is written
	0x 0055	85	Function Relay Parameter 2	inte	R/W/D	
FC 0x 03	0x 0056	86	Relay 1 is turned-on value	inte	R/W/D	Function code 0x 10 is written
	0x 0057	87	Relay 1 turns off the value	inte	R/W/D	
fetch FC	0x 0058	88	Relay 2 is available at a	inte	R/W/D	Function code 0x 10 is written
	0x 0059	89	Relay 2 turns off the value	inte	R/W/D	
0x 10	0x 005A~0x	90~99				

- address 80, 81: 4~The corresponding values of 20mA channels 1, 4mA and 20mA.
- address 82, 83: 4~Corresponding values for 20mA channels, 2, 4mA and 20mA.
- Address 86, 87: on and off value of relay 1.
- Address 88, 89: relay 2 on and off value.

When the above four devices read and write the value of their corresponding register, to judge the multiple relationship between the device correlation and

- Address 47: The backlight mode.
 - 0: Delay shutdown (default value)
 - 1: always on

□ Address 32~36: Correlation, indicating the current device-controlled object. The value of the register represents different objects, reference the floating floating point register address list where the D O mg/L value is object 0, the D0% signal value is object 1, and so on, the temperature value is object 4.

For example, the address 33 register is 4~20mA channel 2 Correlation, with a register value of 4, then 4~20mA channel Current value of 2, controlled by the temperature value.

VII、 Calibration mode

1. Enter the calibration menu



Press in the measurement mode to enter the electrode calibration menu



and press



Or, key Select the point to be calibrated, and press the key



to enter the calibration interface.

The last item in the calibration menu clear calibration data, which lets you clear calibrated information.

The calibration menu interface is operated without a button for a long time, and the instrument will automatically return to the measurement mode.

2. Calibration interface description



The indicator icon of the calibration interface is, refer to the measurement mode and browse mode icons.

3. Instructions for the calibration of the dissolved oxygen electrodes

- ① The dissolved oxygen electrodes can be calibrated at two points, respectively, the environment (100%) in the air, the oxygen content saturated environment and the zero point (0%), the anaerobic environment. Uncalibrated electrodes must be calibrated 100% otherwise incorrect order will be indicated.
- ② The 100% point calibration was successful, and the instrument calculates the electrode slope, expressed as SLOPE, with an allowable range of 50% to 200%.
- ③ The 0% point calibration was successful, the instrument calculates the electrode zero offset and recalculation the two calibrated point slope, the offset is indicated by OFFSET, the allowable range needs to be less than 10% of the saturated current of the electrode used.

- ④ Repeat the 0% point, the successful calibration recalculates the electrode zero offset and uses the original calibration data.
- ⑤ Repeat calibration at 100% points, successful calibration will clear all previous calibration information, recalculate SLOPE, and use the original calibration data.

4. Dissolved oxygen electrode calibration process

- ① Enter the calibration menu, the uncalibrated electrodes should be put in the air or in the oxygen saturation environment, select the air (100%) option in the menu, press the key to enter the calibration interface, and start the calibration. Calibrated electrodes can be calibrated at

zero point (0%) directly from the process ④. 

- ②  The calibration process is fully automatic calibration. After the measurement value is stabilized, the instrument shows the measurement value stability symbol, and the SLOPE is calculated. If the results meet the requirements, the calibration will be successful, otherwise the calibration failure is indicated. Success or not, will be returned to the calibration menu.

- ③ Calibration failure checks the electrode performance according to the error prompt and recalibration after excluding problems. Successful calibration can continue to calibration zero point (0%) according to the subsequent process. If a continued calibration is not required,

press  The key returns the measurement mode.

- ④ Put the electrodes in an anaerobic environment (generally use anaerobic sodium bisulfite solution, commonly known as anaerobic water), select the zero point (0%) option in the menu, press the key to enter the calibration interface, and start the calibration. 

- ⑤ The calibration procedure is the same as ②, fully automatic

this register is set, the temperature set value of the next address 33. If set to 0 (manual), the register set value changes to 250 (25.0°C), and if set to 3 (automatic), the set point changes to 0 (0.0°C).

0: hand movement

3: Automatic NTC22K (default value)

□ Address 33: Temperature supplement setting value. When the temperature supplement type is manual, this register indicates manual temperature value and automatic, this register indicates temperature offset value. This register is a 10-fold value, for example, by reading a register value of 500, it represents 50.0°C. To set a value of -10.0°C, you should write a value of -100.

Manual temperature values are set up to -10.0~130.0°C, temperature offset value set to -10.0~10.0°C.

□ Address 34: Measurement type, the type of measurement value displayed in the measurement interface, setting this register instrument will restore the factory setting and restart. Relay 1 and relay 2 and the 4 to 20 mA transmission current channel 1 are all controlled by this option.

0: Oxygen concentration of DO mg / L

1: percent oxygen content DO%

□ Address 35: Electrode type, setting this register removes the electrode calibration information from factory operations.

0: 400nA

1: 80nA

□ Address 36: Atmospheric pressure, with a set range of 600 to 3000 mBar, with a default value of 1013mBar.

□ Address 37: the pressure in the tank, with a set range of 600 to 3000 mBar, with a default value of 1013mBar.

□ Address 38: Salinity compensation, set range 0.0~40.0g/L, default value of 0.0g / L.

□ Address 45: Digital Filter, Set range 1~24, The default value is 12.

□ Address 46: Language, not affected by factory operations.

0: English

1: simplified Chinese

□ Address 25: Calibration situation register, indicating the calibration point status by binary bit. The register is a 16-bit integer type, and the corresponding relationship between the bit and the calibration point is shown in the following table. If the calibration point is calibrated, the value of the corresponding bit is 1, otherwise it is 0.

The 16-bit whole	BIT15~BIT 2	BIT1	BIT0
Calibration	Unused	Oxygen-free water	In the air (100%)

□ The addresses 26, 27 together constitute the electrode bias data (zero point offset), the electrode successfully calibrates the zero points, and the instrument calculates the electrode bias.

For example, if the address 26 register value is 10, and the address 27 register value is 0x0101 (one decimal digit, in unit of nA), then the offset data is 1.0nA.

□ Address 28: Electrode slope, the electrode is calibrated in the air, and the instrument calculates the electrode slope. The slope defaults 1-bit decimal in percentage.

For example, with a register value of 1001, the slope data is 100.1%

□ Address 30: The local address during communication, the set range of 1~247, the default value is 1, not affected by resuming the factory operation.

□ Address 31: Communication wave rate, set range of 0~4. The corresponding relationship between register value and communication wave rate is as follows, which is not affected by the recovery of factory operation.

0:1200

1:2400

2:4800

3:9600 (Default value)

4:19200

□ Address 32: the temperature supplement type, the instrument has two types of temperature supplement, manual and automatic, where the automatic temperature supplement mode is NTC22K, the corresponding relationship is as follows. After

calibration, waiting for measurement to stabilize values, and calculate OFFSET and SLOPE. After the prompt for success or failure, return to the calibration menu. If it fails, troubleshooting problems can be recalibrated with the prompts.

⑥ After a successful calibration of two points, press  The key returns the measurement mode.

 Note: When waiting for the measurement value to stabilize, if the user keys, the instrument will skip the automatic stability judgment, and calculate the calibration result according to the current display value.

VIII、 Setup mode

1. Enter the Setup menu



Press in the measurement mode. If the instrument does not set the password, directly enter the Settings menu. If the instrument sets the password, it will



enter the password input interface and use it Value setting key () enter password, then key, password is correct, enter the Settings menu, otherwise the password is wrong.

2. Set up the menu button description

① The setting menu consists of three main menus, respectively, for the system setting, parameter setting, operation setting, under the main menu interface,



press Key, can switch between three main orders.



Press the key to return to the measurement mode.



Press key to move the cursor in the menu.



press Key, enter the cursor option.

② After entering the option,



Key, to return to the previous level.

If the current interface selects the interface for the option, press



the cursor, press Key confirmation option.

If the current interface is a numerical setting interface, Set the value



using the value setting key, and press The key confirms the value.

5. Keep register group (40 addresses from 0 x 0014 to 0 x 003 B)

Keep the register for the user settings and electrode calibration information. Read the register value using the function code 0x03, when the instrument is in the setting menu interface 0 x 03 (in the setting state), write the register value using the function code 0x06, which of course must have writable properties to be allowed to write the value. The address list is as follows. Property bar R is readable, W is writable, and D indicates factory recovery This register is restored to the default value.

regist	address	address	name	type	attrib	remarks
keep er	0x0014~0x0018	20~24				
	0x0019	25	Electrode	inte	R/D	Binary bit
	0x001A	26	Electrode	inte	R/D	
	0x001B	27	Electrode bias in	inte	R/D	
	0x001C	28	Electropole slope	inte	R/D	A decimal place,
	0x001D	29				
	0x001E	30	postal address	inte	R/W	See, eleven.5.1
	0x001F	31	Communication	inte	R/W	See, eleven.5.2
	0x0020	32	Temperature fill	inte	R/W/D	See, eleven.4.1
	0x0021	33	Temperature	inte	R/W/D	See, eleven.4.1
	0x0022	34	Measurement type	inte	R/W	See, eleven.4.2
	0x0023	35	The electrode type	inte	R/W/D	See, eleven.4.3
	0x0024	36	atmospheric	inte	R/W/D	See, eleven.4.4
	0x0025	37	Pressure in the	inte	R/W/D	See, eleven.4.5
0x0026	38	Salt compensation	inte	R/W/D	See, eleven.4.6	
FC	0x0027~0x002C	40~44				
0x002D	45	digital filtering	inte	R/W/D	See, eleven.3.3	
0x002E	46	language	inte	R/W	See, eleven.3.1	
0x002F	47	Backlight mode	inte	R/W/D	See, eleven.3.2	
0x0030~0x0031	48~49					
0x0032	50	4~20mA channel 1	inte	R/D	See, eleven.5.5	
0x0033	51	4~20mA channel 2	inte	R/D	See, eleven.5.5	
0x0034	52	Functional Relay	inte	R/D	See, eleven.5.3	
0x0035	53	Relay 1	inte	R/D	See, eleven.5.4	
0x0036	54	Relay 2	inte	R/D	See, eleven.5.4	
0x0037~0x003B	55~59					

	0x0011	17					
	0x0012	18					
	0x0013	19					

① When the temperature compensation is set to automatic, this register is a temperature measurement and set for the user if set to manual.

3. System Settings menu options description

① language

The menu displays the language, optional in Chinese or English.

② Backlight mode

Delay closing: there is key operation, backlight is lit, no key operation in one minute after lighting, backlight is off.

Chang Liang: The backlight is always kept on.

③ digital filtering

Digital filtering is performed by sliding weighted mean filtering and set range 1~24.

The larger the numerical setting, the more stable the data, but the slower the response, suitable for greater interference situations.

④ Change password

When the password has no password set to 0000, measurement mode press SET to directly enter the Settings menu.

The password is set to other values, the measurement mode press SET key to enter the password input interface, the password input is correct, to enter the settings menu.

⑤ Restore the factory

Performing the recovery factory operation, the instrument will clear the calibration information, restore some set parameters to the factory default value, and then restart the instrument.

4. Parameter Settings menu options description

① temperature compensation

Manual: If the instrument is not connected to the NTC22K temperature resistance, choose this option and continue to set the temperature value according to the instrument prompts with the range of -5.0 to 105.0°C.

Automatic: If the instrument is connected to the NTC22K temperature resistance, you can choose this option, when the instrument prompts to set the temperature offset, first do not adjust the value, directly press Confirm key is that the offset is set to 0.0°C. In actual use, if the temperature

deviation between the instrument display temperature and the measured object is found is large, such as the instrument display temperature is 26.0°C and the mercury thermometer is 30.0°C, you can enter the temperature compensation option again, select the automatic option, the instrument prompt to set the temperature offset, and set the value to + 4.0°C, press Confirm key confirmation. Returning to the measurement mode shows the temperature display value becomes 30.0°C, or the measurement value is 26.0°C plus offset set value of 4.0°C. The offset value allows to set a range of -10.0 to + 10.0°C.

② Measurement type

The measurement type is the instrument measurement interface display value, with the optional oxygen concentration (D0 mg/L) or the percentage oxygen content (D0%), and both the relay 1, the relay 2 and the 4~20mA transmission current channel 1 are controlled by this option, Choose good After confirmation, the instrument will resume the factory setting and restart, and run according to the set function. Note: oxygen concentration is indicated as D0 mg / L and D0% indicates percentage oxygen content.

③ The electrode type

The electrode type may be an 80nA electrode or a 400nA electrode, selected according to the electrode used. When selected, the instrument removes the previous electrode calibration information.

④ atmospheric pressure

Atmospheric pressure can be set according to the atmospheric pressure values published by the local meteorological department, and the instrument will automatically calculate the pressure compensation in the measurement to make the measurement results more accurate. Air pressure value Set range is 600 to 3000 m B a r with a default value of 1013mBar.

⑤ Pressure in the tank

in-tank The pressure can compensate for the rise of the electrode in the pressure vessel affected by the pressure, and the user can set the parameter according to the pressure indication value of the pressure vessel, so that the measurement results exclude the factors of the pressure in the

T 0 status, BIT1 indicates the relay 1 status, and BIT2 indicates the relay 2 status

form. Position value is 1, the relay is on and 0, the relay is off. The following table shows.

The 16-bit whole	BIT15~BIT 3	BIT2	BIT1	BIT0
Relay status	Unused	electric relay 2	electric relay 1	Functional

4. Floating floating-point register group (20 addresses from 0 x 0000 to 0 x 0013)

Floating floating point register is floating point data for the measurement and transmission current values of the meter. Access using function code 0x03 with address list below. The tribute bar R indicates readable and W is writable.

One data in the table occupies two register addresses, and when reading the data, two register addresses need to be read at a time to form a floating-point data.

regist er	address hexadecimal	address decimal	name	scope	explain	attribute	remarks
float Floati ng point type regist er	0x0000	0	D0 mg/L price	0.00~40.00	Floating point type	R	Over the upper limit of 40.01
	0x0001	1					
	0x0002	2	D0, % price	0.00~400.0	Floating point type	R	Over the upper limit of 400.1
	0x0003	3					
	0x0004	4	sensor signal	0~2000	Floating point type	R	Over the upper limit of 2001
	0x0005	5					
	0x0006	6					
	0x0007	7					
	0x0008	8	temperature scale ①	-10.0~130.0	Floating point type	R	Over the upper limit of 130.1
	0x0009	9					
FC 0X03 fetch	0x000A	10					
	0x000B	11					
	0x000C	12					
	0x000D	13					
	0x000E	14	4~20mA channel 1 current value	4.00~20.00	Floating point type	R	Over the upper limit of 21.00
	0x000F	15					
0x0010	16	4~20mA	4.00~20.00	Floating	R	Over the	

register	address hexadecimal	addresses decimal	name	scope	type	attribute	remarks
float integer register FC 0X04 fetch	0x0000	0	D0 mg/L price	0~4000	integer	R	Over the upper limit of 7FFF
	0x0001	1	D 0 mg/L value decimal and unit		integer	R	
	0x0002	2	D0, % price	0~4000	integer	R	Over the upper limit of 7FFF
	0x0003	3	D0% value decimal number and unit		integer	R	
	0x0004	4	Sensor signal value	0~2000	integer	R	Over the upper limit of 7FFF
	0x0005	5	Sensor signal value decimal number and unit		integer	R	
	0x0006	6					
	0x0007	7					
	0x0008	8	temperature scale ①	-100~1300	integer	R	Over the upper limit of 7FFF Over the lower limit of 8,000
	0x0009	9	Temperature value decimal number and unit		integer	R	
	0x000A	10					
	0x000B	11					
	0x000C	12					
	0x000D	13					
	0x000E	14	Channel 1 current value	400~2000	integer	R	Over the upper limit of 2,100 Ultra-lower limit 370
	0x000F	15	Channel 1 current value decimal number and unit		integer	R	
	0x0010	16	Channel 2 current value	400~2000	integer	R	Over the upper limit of 2,100 Ultra-lower limit 370
	0x0011	17	Channel 2 current value decimal number and unit		integer	R	
	0x0012	18	Relay status ②		integer	R	binary bit
0x0013	19						

① When the temperature compensation is set to automatic, this register is a temperature measurement and set for the user if set to manual.

② Relay status register represents the relay status in binary mode, the register value is 16-bit integer type, the tenth position BIT0 means the B I

tank. in-tank Pressure value Set range is 600 to 3000 m B a r with a default value of 1013mBar.

⑥ Salt compensation

Salinity compensation can be measured by the user for the salinity value of the measured water sample, and then set in this menu to accurately correct the measured results of dissolved oxygen to make the measurement data more accurate. Salt degree value Set the range 0.0~40.0g/L, with a default value of 0.0g / L.

5. Run the settings menu options description

① postal address

Native address during RS485 MODBUS communication. Set the range of 1~247.

② Communication Porter rate

RS485 MODBUS communication rate, optional 1200, 2400, 4800, 9600, 19200.

③ Functional relay

The function relay can be set to the alarm mode or the cleaning mode.

Alarm mode: suitable for external alarm device, relay 1 and relay 2 either closed, the functional relay closed.

Cleaning mode: suitable for external cleaning equipment, first set cleaning interval, set range of 1~1000 hours, then set cleaning duration, set range of 1~1000 seconds.

④ Relays 1 and relay 2

The two relays are associated with the DO % measurement value, and the DO mg/L measurement value under the DO mg/L measurement function.

The two relays are set in the same way. After entering the relay option, you need to set an on value and then a turn-off value. The setting range of the two values is the same measurement range as the relevant measurement amount, and the on and off values cannot be the same. details are as follows:

Under the DO % measurement function, the setting range of the two values ranges from 0.0 to 400.0 %.

Under the DO mg / L measurement function, two values range 0.00~40.00mg/L.

⑤ 4~20mA channel

4~The 20mA channel 1 output current value is at The DO % measurement function is associated with the DO % measurement function, and the DO mg / L measurement value under the DO mg / L measurement function.

4~The 20mA channel 2 output current value and temperature measurement Value correlation.

two4~20m4~20mA channel is set in the same way, entering4~20mA channel After the option, set the corresponding value of 4mA and then 20mA. The set

From the machine	FC +0x80	error code	CRC verification
1 byte	1 byte	1 byte	2 byte

⑤ Error code description:

0x01: Wrong function code, and received an unsupported function code.

0x02: Wrong register address and wrong register address to be accessed.

0x03: Wrong number of registers and registers to access are out of range.

0x04: The modified value is beyond the register value.

0x05: Verification error, and the CRC check value is incorrect.

0x06: Write error, the target register does not support the write operation.

3. Floating whole register group (20 addresses from 0x0000~0x0013)

The floating integer register is the integer data of the measurement value and the transmission current value of the instrument. Access using function code 0x04, the address list is listed below. The tribute bar R indicates readable and W is writable.

A measurement in the table consists of two parts, values in part, decimal and units in part.

For example, the address 0x0000 register is the integer form of oxygen value, the address 0x0001 register is decimal places and unit of oxygen value, where high byte value is used to represent decimal places, low byte value means unit, obtained by the query unit control table. If you read the 0x0000 register value is 0x02BC (decimal 700), 0x0001 register value is 0 x 0020E, where 02 indicates 2 decimal places and 0 E indicates unit mg/L, then the current dissolved oxygen value is 7.00 mg/L.

format for different register groups.

Host instruction format

From the	FC	Read the starting address	Number of number of read	CRC
1 byte	1 byte	2 byte	2 byte	2 byte

Next-bit machine reply format

From the	FC	Returns the total number	N register data	CRC
1 byte	1 byte	1 byte	N*2 byte	2 byte

② Function code 0x06 modifies a register value.

Host instruction format

From the	FC	Change the address of the	modified value	CRC
1 byte	1 byte	2 byte	2 byte	2 byte

Next-bit machine reply format

From the	FC	Change the address of the	Modified values	CRC
1 byte	1 byte	2 byte	2 byte	2 byte

③ The function code 0x10 modifies the multiple consecutive register values, the instrument can only be used to modify the two consecutive register values, and only a few fixed registers can be modified.

Upper computer command format, here to modify two registers for example, N=2 in the table below.

slave address	FC	revise Register start address	revise Register Number of N	modified value Bytes occupied by N * 2	first register modified value	the second register modified value	CRC verification
1 byte	1 byte	2 byte	2 byte	1 byte	2 byte	2 byte	2 byte

Next-bit machine reply format

From the	FC	Change the address of	The number of modified	CRC
1 byte	1 byte	2 byte	2 byte	2 byte

④ Error response, the next machine receives an error instruction, and will reply in the following format.

range of the two values is the same as the relevant measurement range, and the minimum interval between the two values is 200 words, as follows:

Channel 1 Under the DO % measurement function, the two values are set up ranging from 0.0 to 400.0 % with a minimum interval of 20.0 %.

Channel 1 is under the DO mg / L measurement function with two set range 0.00~40.00mg/L with a minimum interval of 2.00mg / L.

The setting range of the channel 2 two values is-5.0 to 105.0°C, with a minimum interval of 20.0°C.

6. Set the menu options default value list

If the value in the table is affected by the recovery factory operation, perform the recovery factory operation, and this option becomes the default value. It will not change otherwise.

menu	option	Windows default	Whether it is affected by resuming the factory operation
System settings	language	the Chinese language	deny
	Backlight mode	Delay closed	yes
	digital filtering	12	yes
	Change password	0000 (No password)	deny
parameter setting	temperature	Automatic temperature compensation,	yes
	Measurement type	D0 mg/L	deny
	The electrode type	400nA	deny
	atmospheric pressure	1013mBar	yes
	Pressure in the tank	1013mBar	yes
	Salt compensation	0.0g/L	yes
Run settings	postal address	1	deny
	Communication Porter	9600	deny
	Functional relay	Cleaning function, 1 hour interval	yes
	electric relay 1	The on value is 0.00 mg/L or 0.0% The off value is 40.00mg/L or 400.0%	yes
	electric relay 2	The on value is 0.00 mg/L or 0.0% The off value is 40.00mg/L or 400.0%	yes
	4~20mA channel 1	The 4mA corresponds to a value of 0.00 mg/L or 0.0% The 20mA corresponds to a value of 40.00mg/L or 400.0%	yes
4~20mA channel 2	The 4mA corresponding value is-5.0°C The corresponding 20mA value is 105.0°C	yes	

IX、informative pattern



In the measurement mode, the key can enter the information mode, which can browse the instrument setting parameter value and instrument information. There are the current page and the total page number prompts on the top right of the display interface, such as 1 / 9, the current first page, a total of 9

pages, and Symbol prompt can press Key page to browse.



The key can return to the measurement mode. If there is no key operation for a long time, the instrument automatically returns to the measurement mode.

X、communicating protocol

1. Newsletter profile

The instrument adopts the RS485 hardware interface Modbus-RTU communication protocol. Data format N, 8, 1, that is, no parity, data 8 bits, stop bit 1 bit. The factory default native address is 1, and the baud rate is 9600. The address can be set in the range of 1 to 247, and the port rate is optional at 1200, 2400, 4800, 9600, 19200, which the user can set itself based on demand.

2. data format

The function codes used in the communication include 0x 03, 0x 04, 0x 06 and 0x10. Here is only a brief introduction of the corresponding data frame format of the function code used. If you know more, you can query the Modbus-RTU related information by yourself.

One register in the data accounts for two bytes.

The floating-point numbers are represented by two registers, namely 4 bytes.

The integer data is represented by a register with high bytes before, low bytes after, and negative numbers in complement form, x FFFF 0, -1.

① Function codes 0x03 and 0x04, read register content, the same instruction